

Intelligent Visual Surveillance (Ivs) For Intruder Detection

Dr. P. Alli¹ P. Chandra²

¹Professor and Head of CSE Department, ²Final year ME (CSE) Velammal College of Engineering and Technology, Madurai, Anna University, Chennai, India.

ABSTRACT

Intelligent visual surveillance (IVS) is an automated visual monitoring process which involves analysis and interpretation of object behaviors. Nowadays, it is easy to keep a guard outside the shop for security but always we cannot rely on guards. This concept is implemented for continuous surveillance, automatic person detection and intimidation. The hardware section runs with ARM controller, surveillance camera, and person detection sensor. The PIR sensor used to detect human motion and the controller signal turns on the surveillance camera to capture the image. Communications between control room and monitoring unit are accomplished through GSM Communication.

Keywords: PIR Sensor, Microcontroller, Web camera activation, video surveillance, GSM.

I. INTRODUCTION

Intelligent Visual Surveillance (IVS) is an automated visual monitoring process. Three types of Visual surveillance activities are manual, semi-autonomous and fully-autonomous. Monitoring of live video for long duration by human operator in order to get useful information is impractical and we cannot rely on security guards for all time. In our modern world, there is a necessity to implement intelligent system for automatic detection of intruder. This paper describes an Intelligent Visual Surveillance (IVS) system for intruder detection. PIR sensor is used to detect human.

II. RELATED WORKS

Pyroelectric Infrared Sensor (PIR) used to identify the presence of people in particular place by using infrared level. Autonomous robotic vehicle moves in the earthquake prone area and helps in identifying the live people and also used in rescue operations. Hence valuable life of people can be saved by detection in natural calamities even without the help of large number of rescue operators. Ultrasonic sensor module contains a transmitter and a receiver, which is placed in a line direction. Because the ultrasonic transmission will spread at a beam angle, we can use multiple ultrasonic receivers to receive the ultrasonic transmission. If any intruder passes through the ultrasonic sensing area, the human body blocked the transmission of ultrasonic waves. If the receivers do not receive any transmission from the ultrasonic transmitter, the system will sense when someone is passing through the surveillance area. Another surveillance works is Majority Voting Mechanism (MVM) which use group of sensors. It depends on majority voting system. If over half the sensors in a sensor group sense a signal blocking, the majority voting program starts the Web camera.

III. PROPOSED METHOD

This paper describes an intruder detection system based on PIR sensors which are installed on the wall of a protected room in a shop. PIR sensor detects changes in the heat level. This is the way to detect people if they entered in the protected room. It produces digital output and it can be directly given to the digital pins. When motion is detected the PIR sensor outputs a high signal on its output pin. This logic signal can be read by a microcontroller, it produce a signal and send it to the control center.

IV. BLOCK DIAGRAM

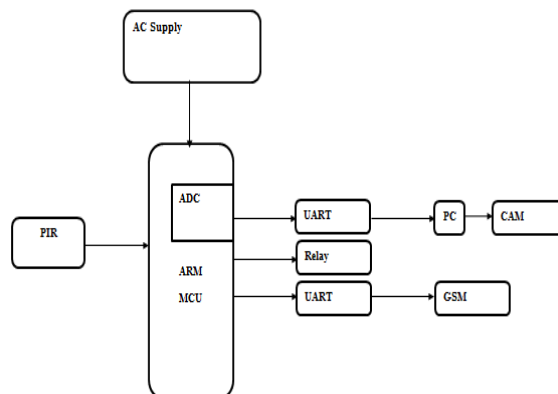

Fig: 1 Intruder Detection System

Pir:

Pyroelectric Infrared sensor is called as PIR sensor. It just receives the infrared ray that is emitted by the objects. It is a passive sensor which doesn't emit the infrared ray. That's the main reason of using PIR sensor over IR sensor because IR sensor cannot transmit over long distance. PIR sensor detects the motion by checking for a sudden change in the surrounding IR patterns.

Microcontroller:

Advanced RISC Machine (ARM) LPC2148 is the microcontroller used in the concept. ARM controller is a low power consumption processor which works on 3.3V power supply. And its performing more millions of instruction per second (MIPS). Embedded C is used for programming the microcontroller. Signals from PIR sensors are given to the microcontroller.

MAX3232:

MAX3232 is used for serial communication and it converts the signal (RS232) to TTL logic and vice versa.



Fig: 2 MAX3232

MAX3232 is a 3.3 volt version of the MAX232 and is also 5 volt tolerant serial communication. It is mainly used in RS232 Communication with modems, printers, PC applications.

Gsm:

GSM (Global System for Mobile) TTL Modem is SIM900 Quad-band device, and it works on frequencies of 850, 900, 1800 and 1900 MHZ. The communication for the system and GSM can be done through serial communication. The serial communication creates an interface through which it convert CMOS to TTL logic. The GSM is used to send the alert message to the control room.

V. WORKING

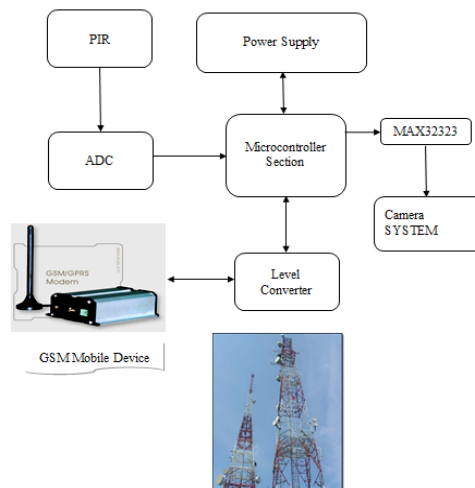

Fig: 3 System Architecture

PIR sensor used to detect motion by measuring changes in the infrared (heat) level and it's connected with the amplifier. If any intruder enters the secured area then the PIR sensor sends the signal to ARM controller by use of amplifier. Amplifier carries the resistor and transistor which is used to control the signal flow. Voltage regulator converts the voltage (input) in to 5V and it's connected with Advanced RISC Machine (ARM) microcontroller. It is a low power consumption processor which works on 3.3V power supply. MAX3232 serial chip connected with the ARM controller which is mainly used in RS232 Communication with modems, printers, PC applications.

Finally the serial cable sends the signal to surveillance system. This signal turns on the web camera to capture the intruder image automatically. The GSM is used to send the alert message to the control room. The message includes the location, time and other details. This message helps the user and the controller about the intruder.

VI. CONCLUSION AND FUTURE WORK

This paper describes an automatic visual surveillance system based on embedded system; it integrates the technology such as PIR sensor and microcontroller in order to reduce power consumption and manual controlling method. The PIR sensor signal can be read by microcontroller, it turns on the web camera to capture the image. The GSM modem is used to send the SMS alert to the authority or control room. The next evolutionary step is to improve the accuracy and reduce the environment noise.

VII. RESULT ANALYSIS

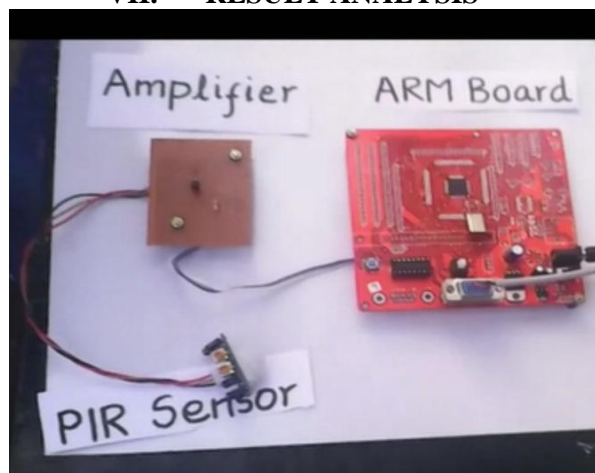
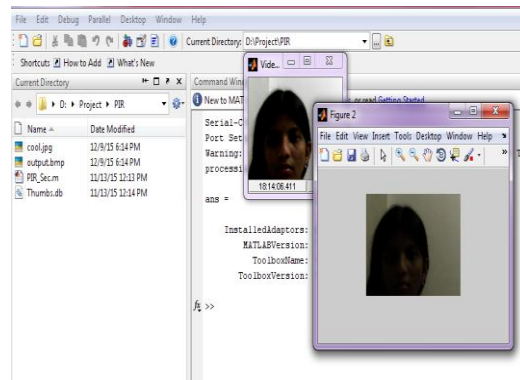

Fig: 4 Hardware Model

If any intruder enters the secured area, the controller sends the signal to the system and its turns on the web camera to capture the image. GSM modem sends the SMS alert to the authority.



REFERENCES

- [1]. Subitha M. B “Microcontroller Based Tracking System” IJEDR , Volume 2-2014.
- [2]. RupnarPallaviSharad ,“Live Human Detecting Robot for Earthquake Rescue Operation,” International Conference on Computer Vision, 2013.
- [3]. DongfengXie, Huawei Liu, Baoqing Li, Qianwei Zhou and XiaobingYuan ,“Target Classification Using Pyroelectric Infrared Sensors” International journal on smart sensing and intelligent systems vol. 6, no. 5, december 2013.
- [4]. Yang Wang,“Real-Time Moving Vehicle Detection With Cast Shadow Removal in Video Based on Conditional Random Field” vol. 19, no. 3, march 2009.
- [5]. Lu J, Gong J, Hao Q, Hu F (2013) Space encoding based compressive multiple human tracking with distributed binary pyroelectric infrared sensor networks.In: Proceedings of IEEE Conference on MFI 181–185.
- [6]. Michael Oren TomasoPoggio, “A General Framework for ObjectDetection”, IJSCE, 2013.
- [7]. K. Rajalakshmi and R.Chakrapani “Home Surveillance system using Ultrasonic Sensors” International journal of Scientific & Engineering Research,May-2013.
- [8]. Bo-Hao Chen and Shih-Chia Huang “An Advanced Moving Object Detection Algorithm for Automatic Traffic Monitoring in Real-World Limited BandwidthNetworks”IEEE transactions on multimedia, vol. 16, no. 3, april 2014.
- [9]. K. Kuhnly, “A technical overview of pir motion detection,” Tech. Rep., ITI Technologies Inc, 2000.
- [10]. S. Bahadori, L Iocchi "Human Body Detection in the Robocup Rescue Scenario", Roma
- [11]. M. Saini, X.Wang, P. K. Atrey, and M. Kankanhalli, “Adaptive workloadequalization in multi-camera surveillance systems,” *IEEE Trans.Multimedia*, vol. 14, no. 3, pp. 555–562, Jun. 2013.